

**IMPORTANT**

All *California Faucets*® products are engineered to provide quality performance provided they are installed and operated properly. To fully enjoy the comfort, safety, and reliability of your new PBTS or PBS Valve, please follow the instructions below.

**Standard Installation**

Before installing, please check local plumbing codes to verify permissible dimensions.

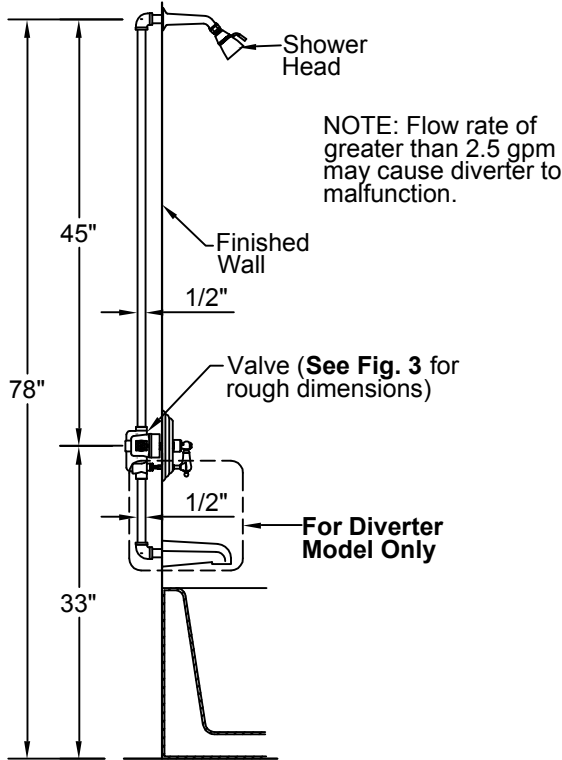

Fig. 1

**Rough In Dimension**

Finished wall to end of Broach = 3 1/4"  
Applies to both PBTS and PBS Valves

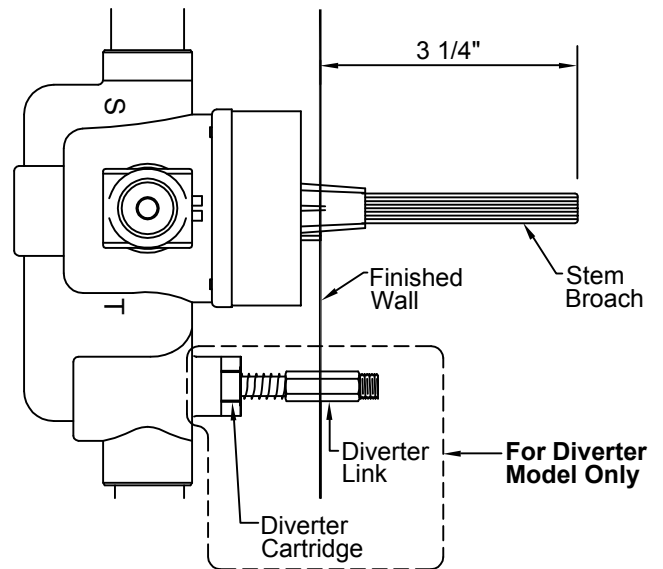

Fig. 3

PBTS Valve Shown

**PBS/PBTS Flow Rate Vs. Inlet Pressure.**

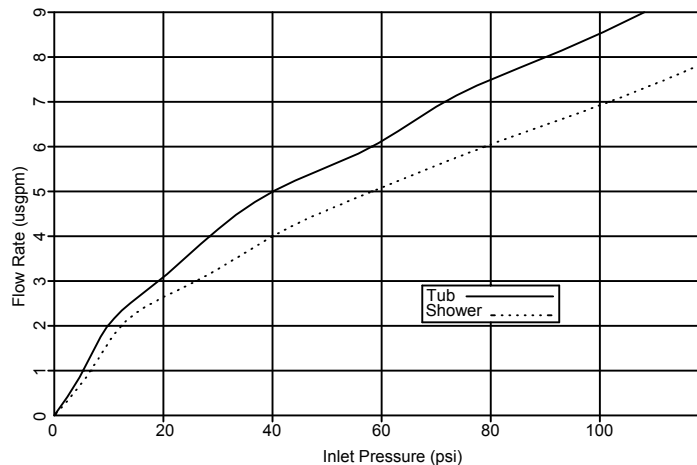

Fig. 2

**Operating Pressure**  
Min. Operating Pressure = 20 psi  
Max. Operating Pressure = 125 psi

## Installation:

**NOTE:** Failure to follow these instructions may cause damage or improper operation and nullify the warranty!

### 1 ROUGH IN:

Position valve with the 1/2" shower outlet marked "S" up and the 1/2" tub outlet marked "T" down. Finished wall to tip of broach should be 3 1/4" (See Fig. 3, previous page).

Plastic installation cover must remain installed for finished wall surface measurements and as a template for plastering and/or tiling (See Fig. 4) Cut-out hole diameter around valve to be 6 1/4"

### IMPORTANT NOTES:

- It is not necessary to remove the pressure balancing cartridge from the valve during normal soldering of connections.
- When soldering copper by copper connections do not use excessive heat as this may cause damage to internal seals. A propane gas torch is recommended. **DO NOT USE OXYGEN/ACETYLENE TORCH!**
- To test the pipe joints, pressurize both hot and cold lines.

### 2 FINISH:

- After plastering and/or tiling is complete, remove plastic installation cover and plastic diverter cover (if applicable) - See Fig. 4. Make sure stem broach (See Fig. 8) is completely in the off position. (Fully rotate clockwise)

### 3

Install Diverter Trim (for Tub/Shower Diverter units only) - See Fig. 5.

- Screw finished diverter stem (#3) onto brass hexagonal diverter link (#2).
- Screw on sleeve (#4).
- Fit faceplate, screws, and diverter knob/button (#5).

### 4

Insert handle onto broach and secure by tightening the set screws with the supplied allen wrench.

**NOTE:** Some installations may require the installer to trim the stem broach for a correct fit (See Fig. 7a)

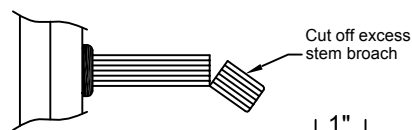
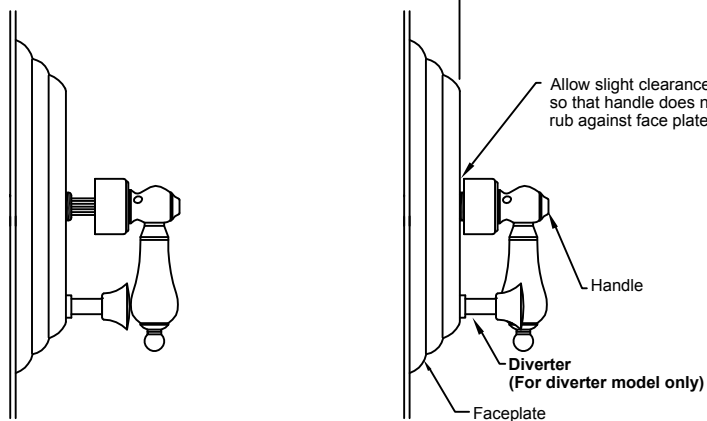

Fig. 7a



INCORRECT

CORRECT

Side View

Fig. 7

Diameter wall cut-out hole around valve = 6 1/4"

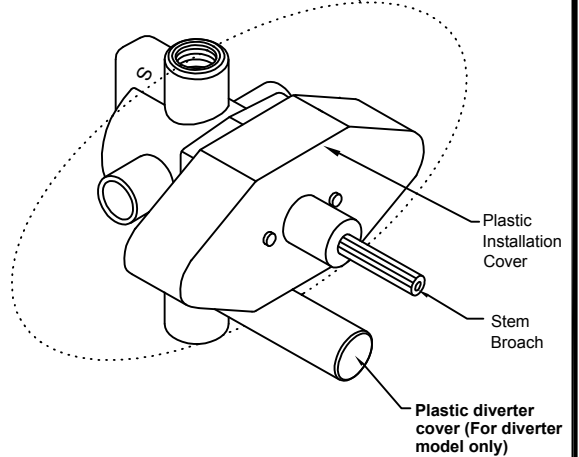
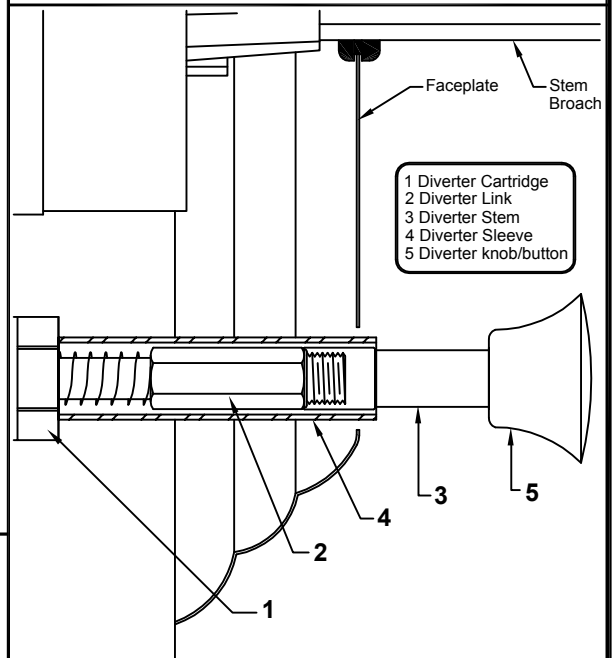

Fig. 4



Side View - Diverter Detail

(For diverter model only)

Fig. 5

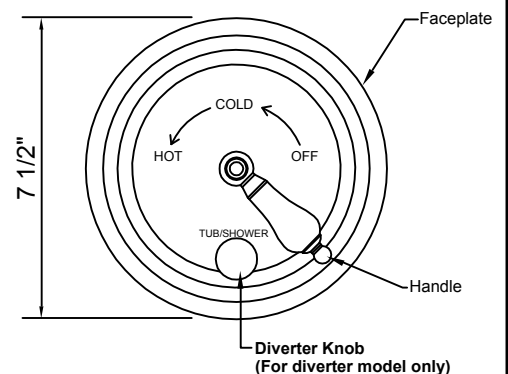

Front View

Fig. 6

## Adjusting the Temperature Limit Stop:

All *California Faucets* pressure balance valves are equipped with a Temperature Limit Stop. This device (see Fig. 8), can be adjusted to limit the maximum temperature of the water delivered by the valve. The Temperature Limit Stop is set at the factory in a neutral position. Set or adjust as follows:

- 1 Remove handle, screws, and faceplate to expose the valve in the wall.
- 2 Rotate stem broach clockwise to fully closed position ( See Fig. 8).
- 3 Remove stem broach by inserting a long, narrow Phillips head screw driver into the center of the broach and unscrewing the internal screw. Lift off thin brass temperature limit stop (See Fig. 9). Rotate stem broach fully closed and make sure mechanical stop is to the right against stop post ( See Fig. 8). Rotate broach counter clockwise until the desired maximum temperature is reached. Replace temperature limit stop so it rests at the left side of the stop post ( See Fig. 11).
- 4 Rotate stem broach fully clockwise to close valve.
- 5 Re-install broach and internal screw.
- 6 Test system and readjust as necessary.
- 7 Re-install faceplate, screws and handle. (Also diverter knob if PBTS valve).

## Filter Removal & Cleaning:

All PBS & PBTS valves are equipped with filters that prevent debris from clogging the pressure balancing cartridge. If these filters become clogged, you will notice a decrease in flow from the valve. The filters can be easily cleaned as follows:

- 1 Remove valve handle, faceplate and stem broach as described above. **Important: Make sure broach is in the off position and note the settings of the mechanical stop and the temperature limit stop (See Fig. 8).**
- 2 Using a screwdriver, turn shut-off stops - if supplied ( See Fig. 4, previous page) 90° to the off position.
- 3 Remove the 4 screws from the valve cover and carefully lift off the cover and pull out cartridge.
- 4 Remove the plastic filter insert and filter by pressing the top corner. This will rotate the filter insert making it easy to remove.
- 5 There is a location on either side of the filter insert where you can get your fingernail under the filter. Pulling away from the filter insert will "pop" the filter out.
- 6 The filter can now be easily cleaned. When clean, place the filter on the filter insert and press gently. The filter will "snap in"
- 7 Inspect the O-ring and apply O-ring grease. Place the filter insert back into the valve body, making sure that the beveled edge of the insert is facing forward. The filter insert should sit flush against the wall of the valve body when properly installed. Insert cartridge make sure the 2 locating pins engage in corresponding holes in body, (make sure H to hot side / C to cold side).
- 8 Fit valve cover and 4 screws. Tighten firmly in diagonal pattern.
- 9 Rotate stem broach fully clockwise, fit mechanical stop and temperature limit stop as above ( See Fig. 8).
- 10 Open shut-off stops (if supplied).
- 11 Test system and readjust as necessary.
- 12 Re-install faceplate, screws and handle. (Also diverter knob if PBTS valve).

## "Back-to-back" or "Reversed" Hot/Cold installation:

- 1 Remove valve handle, faceplate and stem broach, (shut of service stops), and remove valve cover as above.
- 2 Pull the cartridge straight out of the valve body. Rotate the cartridge 180°. Place it into the valve body. Note position of hot "H" and cold "C" markings on the cartridge: "H" hot will now be on the right and "C" cold on left.
- 3 Insert cartridge, re-fit valve cover, mechanical and hot limit stops, broach stem, faceplate, screws and handle as above.

### Closed Position

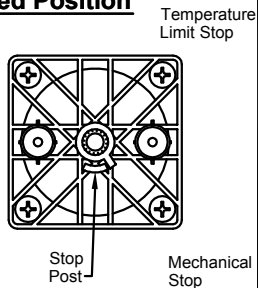

Fig. 8

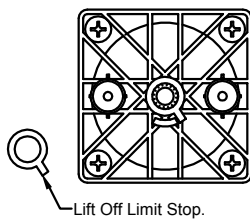
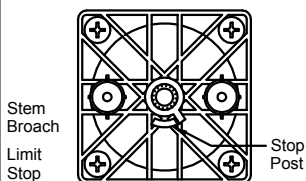

Fig. 9



Rotate stem broach of cartridge counter-clockwise to desired maximum temperature. Place limit stop on stem broach against stop post.

Fig. 10

### On Position

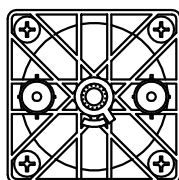

Limit stop hits stop post at highest desired temperature.

Fig. 11

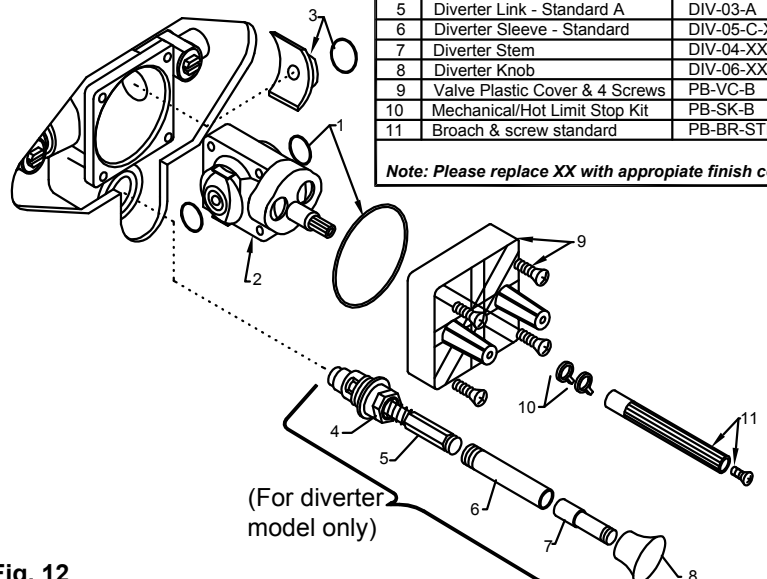

Pos.	Description	CF Part No.
1	O-ring Kit	PB-ORK
2	PBS/PBTS Replacement Cart.	PBS-CART
3	Filter Insert & Filter	PB-FK
4	Pull Diverter Cartridge	DIV-01
5	Diverter Link - Standard A	DIV-03-A
6	Diverter Sleeve - Standard	DIV-05-C-XX
7	Diverter Stem	DIV-04-XX
8	Diverter Knob	DIV-06-XX
9	Valve Plastic Cover & 4 Screws	PB-VC-B
10	Mechanical/Hot Limit Stop Kit	PB-SK-B
11	Broach & screw standard	PB-BR-STD

Note: Please replace XX with appropriate finish code

## Maintenance

This cartridge is designed for the minimum of maintenance in normal domestic use. If a malfunction occurs then this will probably necessitate a complete cartridge replacement. The cartridge contains no internally serviceable parts.

## Troubleshooting

Malfunction	Cause	Remedy
Hot and cold reversed  Tub filler or shower head drips after shutting off the valve.	Hot and cold water supplies have been connected in reverse.  Water remains in the shower piping (This is normal)  Incorrect setting of the mechanical stop, causing a partially opened cartridge.  Cartridge inlet O-rings seal or filter insert O-rings are faulty.	Rotate cartridge as described in "Back-to-back installation".  Allow approximately 3-5 minutes to drain column. <b>Do not try to stop dripping by forcing handle.</b>  Reset the mechanical stop as described in rough-in instruction in <b>Fig. 8-11</b> .  Check the O-rings for cuts or damage and replace if necessary.
Shower insufficiently hot.	Hot limit stop incorrectly set.	Refer to the instructions.( <b>See Fig. 8-11</b> ) Check hot water temperature.
No flow of hot or cold water	Either the hot or cold side is not fully pressurized.  Debris caught inside the inlet filters.	Be sure both hot & cold sides of system are pressurized.  Remove cartridge and flush out or remove any debris lodged inside the hot or cold filters.
Valve body too deep in wall.	Improper installation.	Install the extension kit.

**REMEMBER: NEVER TRY TO STOP DRIPPING BY APPLYING EXCESSIVE FORCE TO THE HANDLE WHEN CLOSING THE VALVE!**