



California Faucets®

Tel: 714-891-7797
Fax: 714-891-2478
Toll Free: 800-822-8855
www.calfaucets.com

THERMOSTATIC VALVES

•TH-150 = 1/2" •TH-175=3/4"

INSTALLATION
INSTRUCTIONS

IMPORTANT

All *California Faucets*® products are engineered to provide quality performance provided they are installed and operated properly. To fully enjoy the comfort, safety, and reliability of your new Thermostatic Valve, please follow the instructions below.

California Faucets reserves the right to make modification and specification changes at any time. Please visit www.calfaucets.com for most current technical data.

Caution: This Thermostatic Valve has no on/off capabilities. It's only function is to mix temperature. A separate stop valve (or stop valves for multiple showerhead applications) must be installed in conjunction with this valve.

Product Features

- Paraffin wax element maintains accurate shower temperature within $\pm 1.8^\circ$ F
- Compensates for water pressure fluctuations. Valve will shut down with loss of either hot or cold water pressure.
- Safety button at 100° F protects against accidental scalding. Manually depress button to exceed 100° F.
- Temperature range is $80^\circ - 110^\circ$ F.
- Ability to dial-in pre-select water temperature saves water.
- High flow rates allow for multiple showerhead applications (See Fig. 1)

Operating Specifications

Operating Pressure

Minimum: 20 PSI

Maximum: 72 PSI

Note: When water pressure exceeds 72 PSI, a pressure regulator is required in the line. Operating pressures (hot and cold supplies) should be kept as balanced as possible for optimal operation of the valve.

Hot Water Supply Temperature

Maximum: 180° F

Minimum: Check for local code requirement.

Flow Rates

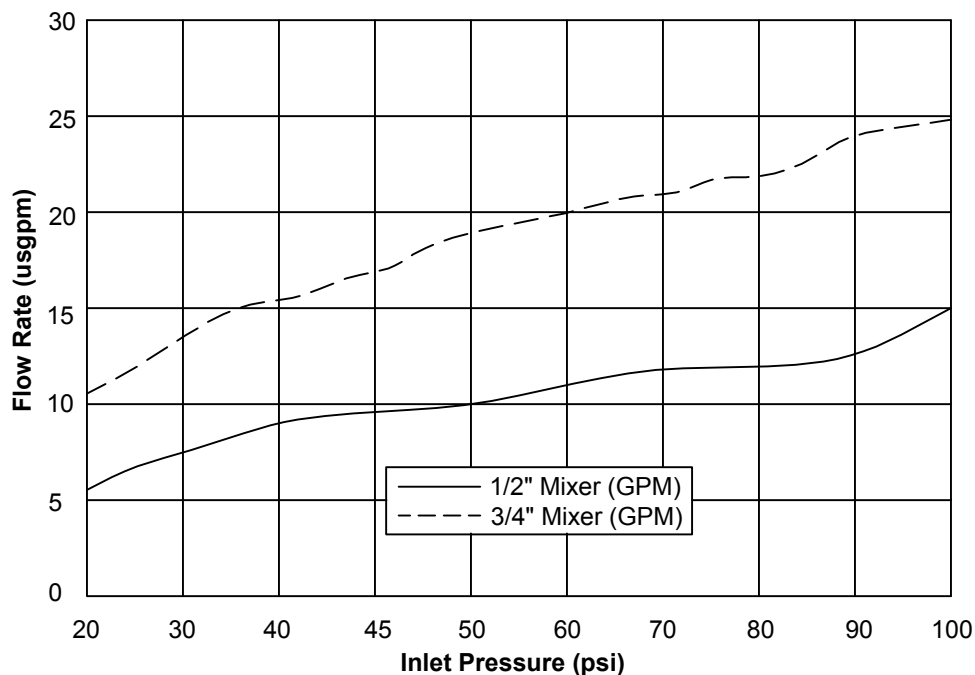

Fig. 1

Installation Instructions

Note: Failure to follow these instructions, or improper operation, may damage the valve and nullify the warranty.

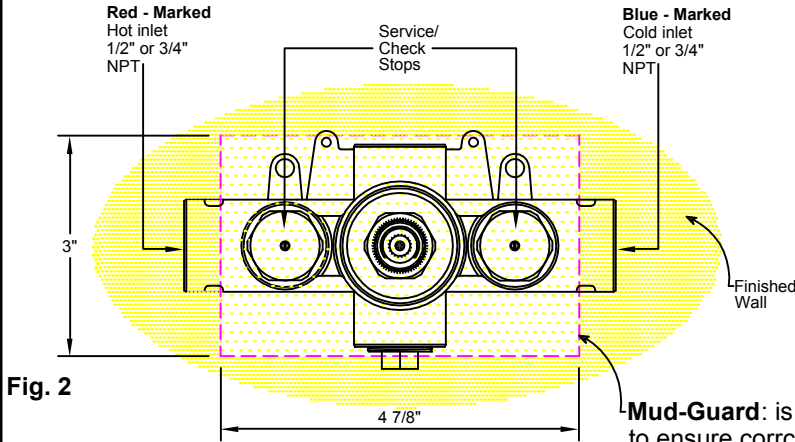

Fig. 2

Front View - Rough Only

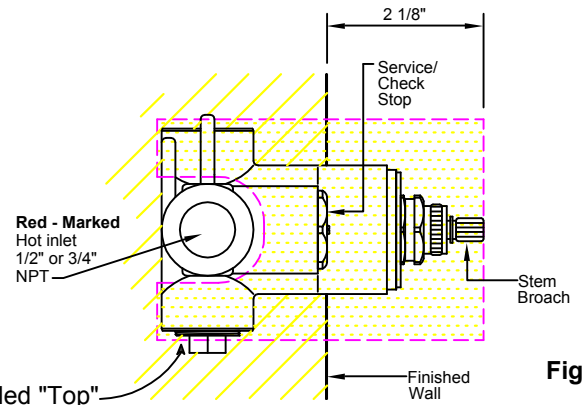

Fig. 3

Side View - Rough Only

Mud-Guard: is labeled "Top" to ensure correct installation.
NOTE: Do not remove mud-guard until installation of trim.
Max. hole cut-out 4 7/8"x3" or faceplate may not cover or seal correctly

1

- Provide properly sized inlet/outlet piping:
- 1/2" pipe for TH-150
 - 3/4" pipe for TH-175

Prior to installing the thermostatic valve to the supply lines, it is crucial to completely flush the lines of all dirt and debris. Failure to completely flush the lines will cause valve failure and will void the manufacturer's warranty.

2

Ensure that valve's hot & cold inlets are installed correctly. They are labeled clearly cold = blue & hot = red. Valve will not function properly if the hot and cold supplies are reversed. (See Fig. 2)

3

Install valve per rough-in dimensions. Make sure the finished wall (including mud & tile) is **2 1/8"** from outside edge of the finished wall to front face of mud-guard (See Fig. 3). Also make sure the sheetrock, tile, etc is installed touching all around the rectangular mud-guard to provide good sealing area for faceplate.

4

Install stop valves between the thermostatic valve and each device to be operated. (note caution on page 1!) See Fig. A - D for some suggested installation diagrams.

5

For multiple shower applications **valve cannot be operated using both top and bottom outlets simultaneously.** This will cause the temperature to deviate. (See Fig. A-D for suggested installation configurations).

6

Install Trim (See Figs. 4-8)
 Ensure that Shroud is installed with indentation mark at 12 o'clock position.
 Ensure that Nylon Stop Ring is installed with red mark at 12 o'clock position
 Ensure that Handle Dial Assembly with Temperature Scale Ring is installed with red safety button at 12 o'clock.

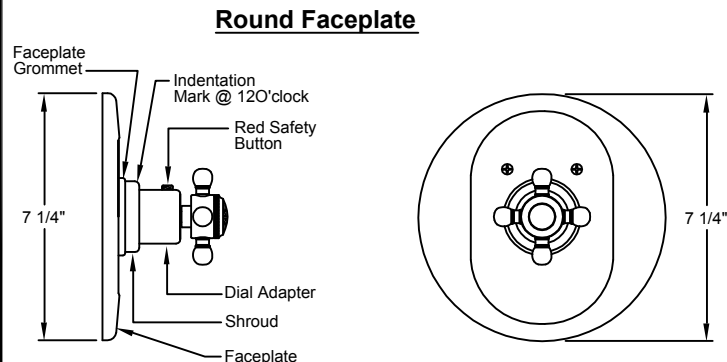

Fig. 4

Installed Trim

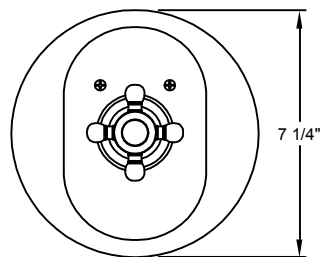

Fig. 5

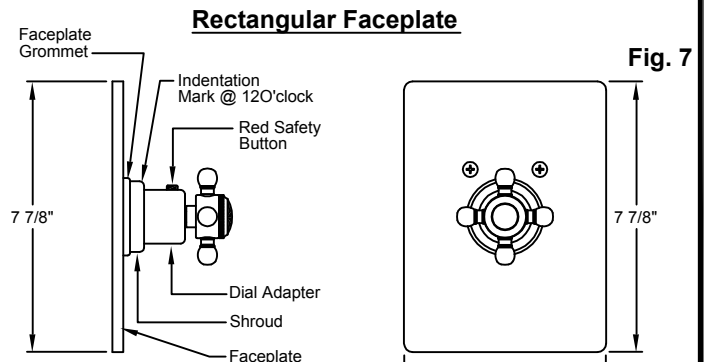

Fig. 6

Installed Trim

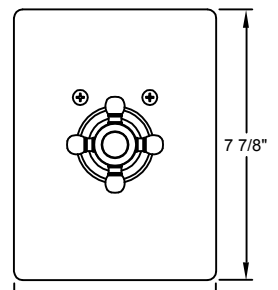

Fig. 7

Initial Calibration of Temperature Setting:

Initial Calibration after installation of thermostatic valve, in-wall stop and showerhead etc.

- 1 Make sure white nylon stop ring is fitted with red mark at 12 o'clock position.
- 2 Open an in-wall stop valve and use a thermometer to measure the water temperature .
- 3 Adjust the temperature by turning the cartridge stem clockwise to decrease / counterclockwise to increase until 100°F ±5°F is reached.
- 4 Install handle dial adapter with red button at 12 o'clock position, and tighten phillips screw (Do not overtighten)
- 5 Install handle and tighten the 2 set screws.

Recalibration

Remove handle, phillips screw and handle dial adapter and follow directions above.

Pos.	Description
1	Valve Body
2	Screw Receivers
3	Service Check Stop
4	Nylon Stop Ring
5	Rubber Gasket
6	Faceplate Round or Rectangular (please specify, see Fig. 5 & 7)
7	Faceplate Screws
8	Faceplate Grommet
9	Shroud O-Ring
10	Shroud
11	Dial Adapter
12	Adapter Screw
13	Decorative Handle
14	Handle Set Screws (pair)

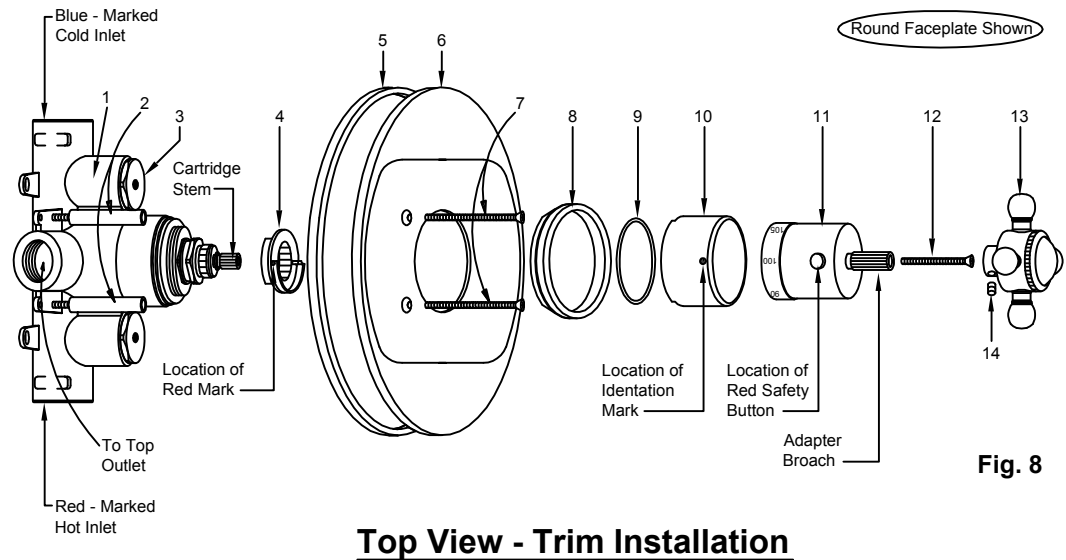

Fig. 8

Valve Maintenance:

You may, after time, notice reduced water flow, inaccurate mixing or the handle may become hard to turn. In this case, you must remove the cartridge for cleaning using the following procedure:

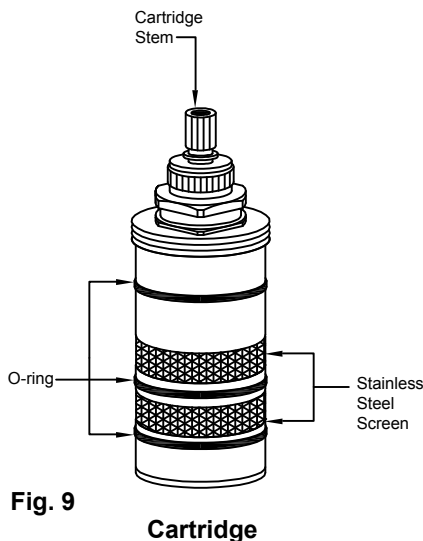

Fig. 9

Cartridge

- 1 Remove the decorative handle by loosening the set screws (See Fig. 8).
- 2 Unscrew and remove phillips screw from stem broach.
- 3 Remove the nylon stop ring.
- 4 Remove all trim (See Fig. 8).
- 5 Using a small slot screwdriver, shut off hot/cold water supplies by gently turning service/check stop screw heads clockwise until resistance is felt. **(Do not apply excessive force). Open a shut off valve to shower head to check if water supplies are shut.**
- 6 Using a wrench, unscrew the cartridge in a counterclock wise direction.
- 7 Remove cartridge.
- 8 Rinse and clean stainless steel screens on cartridge body. (See Fig. 9).
- 9 Grease o-rings.
- 10 Reinstall cartridge into valve body, tighten in clockwise direction.
- 11 Open hot and cold water supplies by turning screw heads of service/check stops fully counter-clockwise, until screw head is flat with face of service stop. Calibrate the temperature settings using the above instructions.
- 12 Install all trim (See Fig. 8).

Note: Because of the "set & forget" capabilities of the thermostatic valve, it is possible that the handle will be infrequently turned. The handle must be turned on an occasional basis to prevent mineral build which can cause the handle to "lock up".

Maintenance

This cartridge is designed for the minimum of maintenance in normal domestic use. If a malfunction occurs then this will probably necessitate a complete cartridge replacement. The cartridge contains no internally serviceable parts.

Troubleshooting

<u>Malfunction</u>	<u>Cause</u>	<u>Remedy</u>
Handle does not turn	Mineral build-up from infrequently used handle	Rotate handle firmly back and forth. Do not use excessive force. If that does not work, remove and clean cartridge to remove mineral build-up.
Hot & cold water does not mix	No water pressure in one of the pipes, Blocked showerhead.	Correct water pressure at the source. Remove showerhead and clean debris from it.
Cannot regulate temperature	Water supply reversed. Valve installed upside down.	Reverse the hot & cold supply lines. Reverse valve.
Water not hot enough	Valve not properly calibrated. Water-heater setting incorrect or hot water supply diminished.	Re-calibrate valve following instructions on page 3. Adjust water heater temperature setting (in compliance with local codes).
Water too hot	Valve not properly calibrated. Water too hot at source.	Re-calibrate valve following instructions on page 3. Adjust water heater temperature setting (in compliance with local codes).
Temperature selected on dial is different than temperature of water coming out of shower head	Valve not properly calibrated. Uneven hot & cold water pressure.	Re-calibrate valve following instructions on page 3. Check and adjust water pressure for both hot & cold water supplies.
Weak water flow	Low water pressure. Cartridge screen blocked. Blocked showerhead.	Check and adjust water pressure. Remove and clean cartridge following instructions on page 3. Remove showerhead and clean debris from it.
Dripping or running showerheads	Faulty stop valve cartridge	Check and repair/replace cartridge in stop valve.

How to Test Thermostatic Cartridge

Turn handle to 100° F and turn off the cold water supply. If operating properly, the cartridge will shut down to a trickle. Reverse procedure shutting off hot water supply, if operating properly, the cartridge will shut down to a trickle. Cartridge is defective if it does not shut off either the hot or cold as described.

Cartridge contains no user serviceable parts. If defective, it must be replaced.

IMPORTANT CLEANING NOTICE

Please refer to *Finish Care Instructions* for complete cleaning information. Wipe frequently with a soft, damp cloth.
Never use acids, harsh abrasives or detergents.

Thermostatic Valve Sample Installations

TH-175 3/4" Valve - 3 Outlet Sample Installation Parts List

- (1) TH-175 3/4" Thermostatic Wall Valve with Trim
- (1) XX-75-W 3/4" In Wall Stop Valve with Trim
- (2) XX-50-W 1/2" In Wall Stop Valve with Trim
- (1) SH-01 Shower Arm and Flange
- (1) SH-04 6 Jetted Showerhead
- (1) SH-10 Wall Elbow With Outlet
- (1) HS-72 72" Hose for Hand Shower
- (1) HS-15 Cobra Hand Shower
- (1) SB-24 Slide Bar
- (1) TS-40 Series 40 Wall Tub Spout

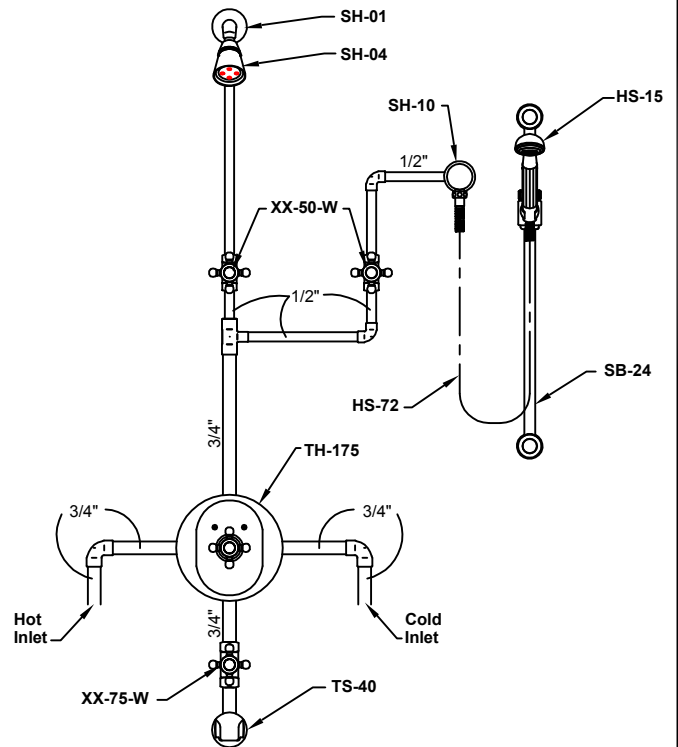

Fig. A

TH-175 3/4" Valve - 3 Outlet Sample Installation Parts List

- (1) TH-175 3/4" Thermostatic Wall Valve with Trim
- (3) XX-50-W 1/2" In Wall Stop Valve with Trim
- (3) RB-01 Body Sprays
- (1) SH-01 Shower Arm and Flange
- (1) SH-05 8 Jetted Showerhead
- (1) SH-10 Wall Elbow With Outlet
- (1) HS-72 72" Hose for Hand Shower
- (1) HS-15 Cobra Hand Shower
- (1) SB-24 Slide Bar

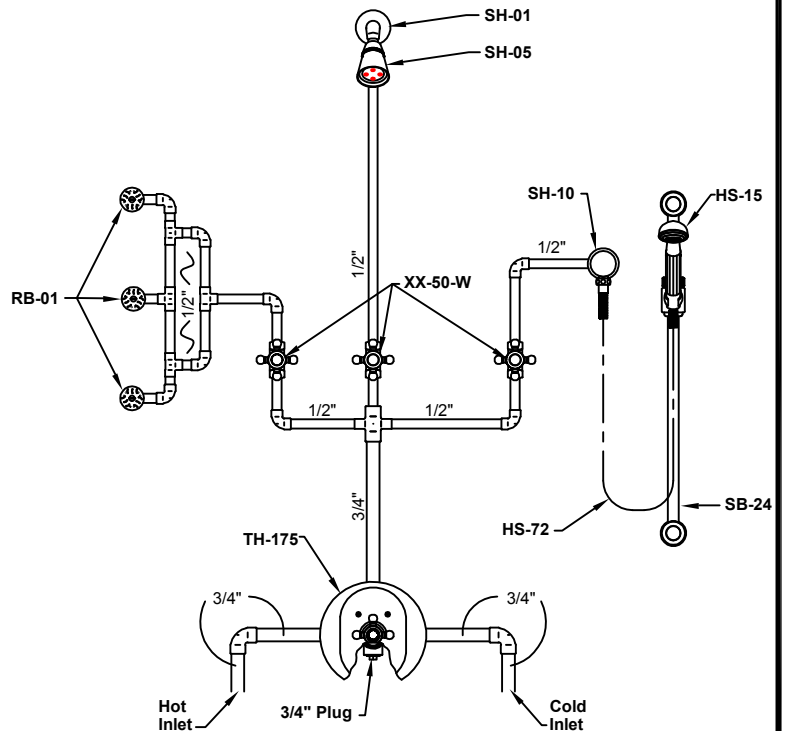

Fig. B

Thermostatic Valve Sample Installations

TH-150 1/2" Valve - 2 Outlet Sample Installation Parts List

- (1) TH-150 1/2" Thermostatic Wall Valve with Trim
- (2) XX-50-W 1/2" In Wall Stop Valve with Trim
- (1) SH-01 Shower Arm and Flange
- (1) SH-05 8 Jetted Showerhead
- (1) SH-10 Wall Elbow With Outlet
- (1) HS-72 72" Hose for Hand Shower
- (1) HS-15 Cobra Hand Shower
- (1) SB-24 Slide Bar

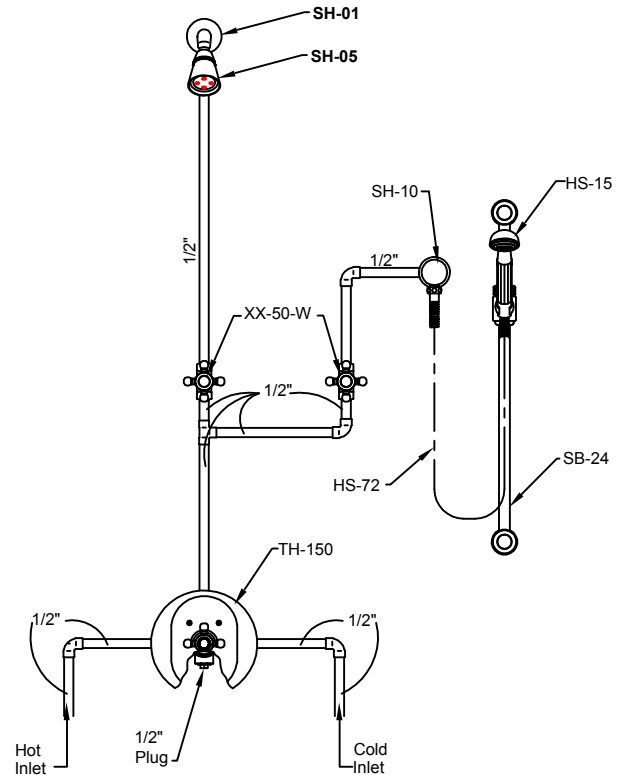

Fig. C

TH-150 1/2" Valve - 4 Outlet Sample Installation Parts List

- (2) TH-150 1/2" Thermostatic Wall Valve with Trim
- (4) XX-50-W 1/2" In Wall Stop Valve with Trim
- (3) RB-01 Body Sprays
- (2) SH-01 Shower Arm and Flange
- (2) SH-05 8 Jetted Showerhead
- (1) SH-10 Wall Elbow With Outlet
- (1) HS-72 72" Hose for Hand Shower
- (1) HS-15 Cobra Hand Shower
- (1) SB-24 Slide Bar

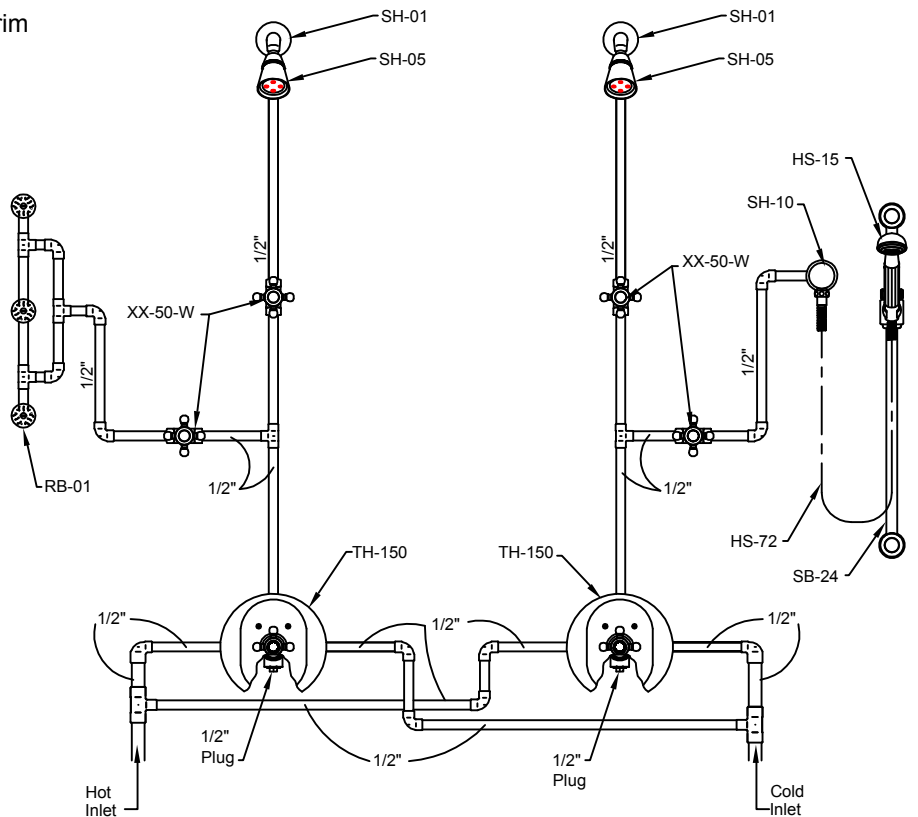

Fig. D